

## IGAADCM07A

### 0.13um Logic 2.5V/1.2V 10bit 1Mhz SAR ADC [8ch]

#### Features

- ◆ 10bit resolution
- ◆ 1Mhz conversion rate
- ◆ Dual supply voltage (2.5V for analog; 1.2V for digital)
- ◆ 8 input channels
- ◆ Single-end input is available
- ◆ Monotonic is guaranteed
- ◆ Power down mode is available
- ◆ Operation temperature range: -40°C~85°C
- ◆ Test chip available in LQFP-64 package
- ◆ 0.13um Logic 2.5V/1.2V CMOS process with 1P8M layout

#### Overview

IGAADCM07A is a general-purpose analog to digital converter (ADC) with 8 multiplexed analog input channels. The ADC architecture is successive approximation register (SAR). The reference voltage and clock signal are all from external source.

A power down mode is available to disable the ADC. It is for lower power dissipation.

#### Block Diagram

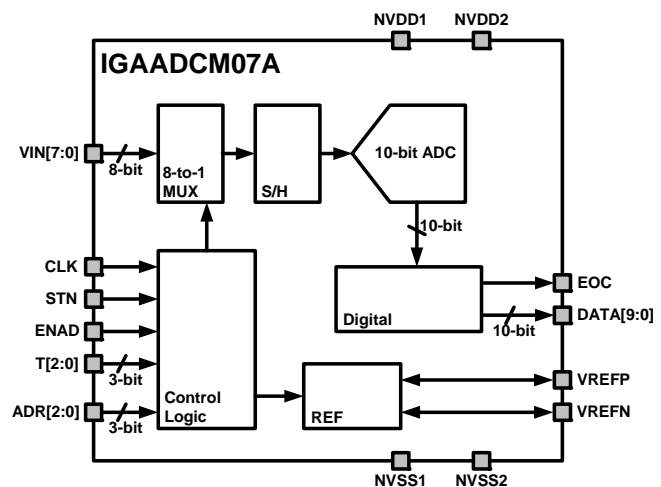

#### Description

The IGAADCM07A is a 10bit analog to digital converter. The analog input voltage was compared to external reference voltages VREFP and VREFN, and then converted to unsigned binary digital code. This ADC sampling rate can be up to 1Mhz with 12Mhz clock frequency. The input full swing of ADC is defined by reference voltages VREFP and VREFN, normally rail-to-rail.

#### *Global Unichip Corp.*

TEL: +886-3-5646600      <http://www.globalunichip.com>  
 FAX: +886-3-5646000      e-mail: [info@globalunichip.com](mailto:info@globalunichip.com)  
 No. 10, Li-Hsin 6th Rd., Hsinchu Science Park, Hsinchu City 300, Taiwan

## **Deliverables**

- Comprehensive document set
- Hard macro
- Synopsys™ synthesis model
- Verilog model
- TLF model
- LEF model
- Testchip and evaluation board

## ***Global Unichip Corp.***

TEL: +886-3-5646600      <http://www.globalunichip.com>  
FAX: +886-3-5646000      e-mail: [info@globalunichip.com](mailto:info@globalunichip.com)

No. 10, Li-Hsin 6th Rd., Hsinchu Science Park, Hsinchu City 300, Taiwan