

UPOR-2503-250

0.25mm 2.5V Power On Reset Circuit (Type III)

Features

- ◆ No external components required
- ◆ Embedded Schmitt trigger for the supply noise rejection
- ◆ With accurate power-good (V_{TH}) and power-fail (V_{TL}) detection
- ◆ Active-low reset signal (RSN)
- ◆ One-shot active-low reset signal (RSPN)
- ◆ Open-drain output (ODRN)
- ◆ Manual reset input (RSNI)
- ◆ Single supply voltage +2.5V
- ◆ Low quiescent current (Typical < 1uA) after re-setting
- ◆ Test chip available in a 48-lead LQFP package

Applications

- Microprocessor reset
- Digital circuit reset

Overview

UPOR-2503-250 is a 2.5-V power-on-reset (POR) circuit designed to monitor the power supplies in microprocessor (μP) and other logic systems. The POR circuit detects the power-good and power-fail conditions of the supply voltage and then issues a reset signal (RSN) to reset the digital core circuits after a fixed delay.

Block Diagram

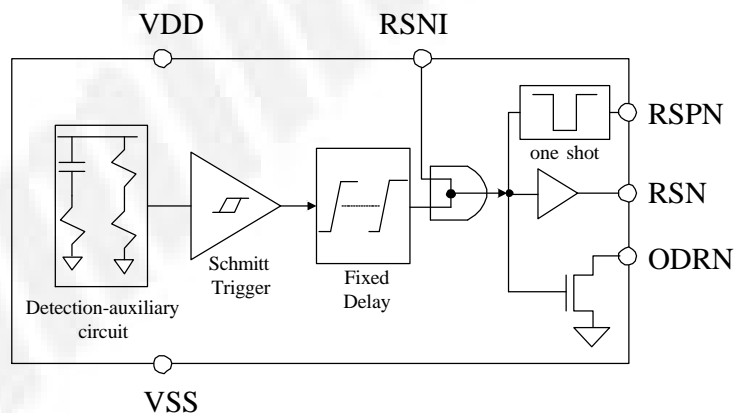

Description

The UPOR-2503-250 is a power-on reset circuit featuring a level-trigger reset signal (RSN), a one-shot reset signal (RSPN) and an open drain output (ODRN). In addition, another optional input pin (RSNI) with an internal pull-up resistor topology is reserved for external reset sources. The UPOR-2503-250 is fabricated in TSMC 1P3M 0.25 μm 2.5V salicide CMOS logic process. The test chip of UPOR-2503-250 is available in a 48-lead LQFP package. Also an evaluation board is available with the test chip.

Deliverables

- Comprehensive document set
- Hard macro
- Synopsys™ synthesis model
- Verilog model
- TLF model
- LEF model
- Test chip
- Evaluation board